

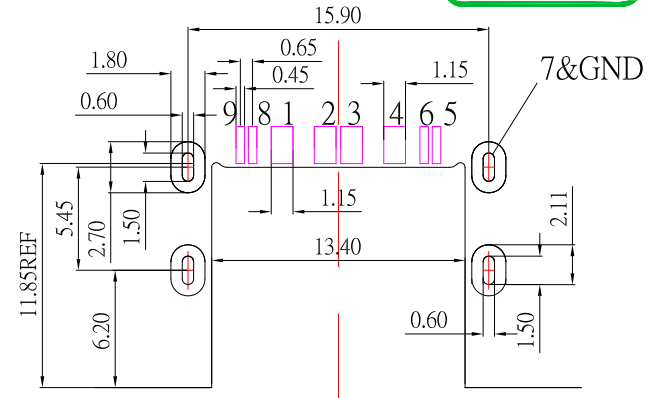

# SUA-110E16-32x-S242

鍍層厚度：  
Blank : 1u"  
2 : 15u"  
3 : 30u"



## RECOMMENDED PCB LAYOUT

### NOTE:

- 1.MATERIAL:
  - 1.1 Housing: LCP
  - 1.2 Contact: Phosphor Bronze
  - 1.3 Shell: SUS
- 2.Finish:
  - 2.1 Contact: Plated Gold in Mating Area ;  
Tin Plated on Solder Balls ;  
Nickel under plated overall
  - 2.2 Shell: Nickel under Plated surface layer
- 3.SPECIFICATION:
  - 3.1 Rate: 3.0 A
  - 3.2 insulator Resistance:1000MΩ Min
  - 3.3 Dielectric Strength: 500V AC
  - 3.4 Contact Resistance: 30mΩ Max
  - 3.5 Operation Temperature: -25°C ~ +85°C
  - 3.6 Insertion Force: 35 N
  - 3.7 Extraction Force: 10 N

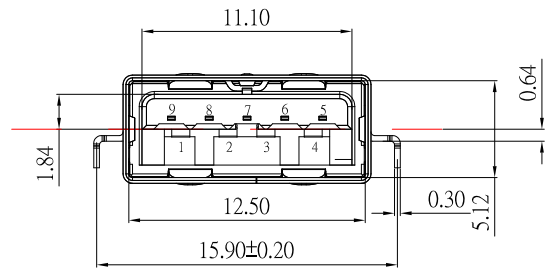
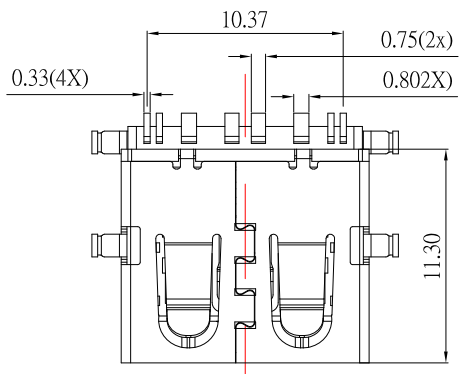
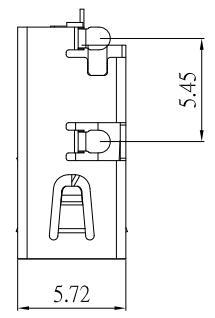
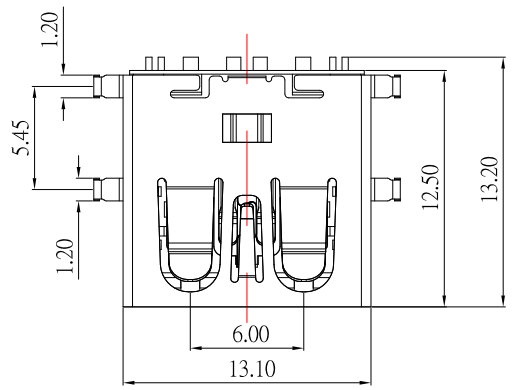
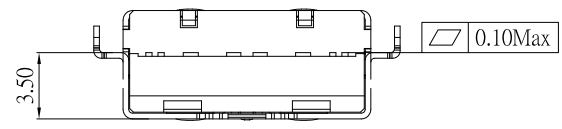

| Pin NUMBER | SIGNAL NAME |
|------------|-------------|
| 1          | VBUS        |
| 2          | D-          |
| 3          | D+          |
| 4          | GND         |
| 5          | StdA_SSRX-  |
| 6          | StdA_SSRX+  |
| 7          | GND_DRAIN   |
| 8          | StdA_SSTX-  |
| 9          | StdA_SSTX+  |
| Shell      | Shield      |

**CONTACT** 建倚科技股份有限公司  
**CONTACT TECHNOLOGY CORP.**

TOLERANCE UNLESS OTHERWISE STATED :  
Up to 5 ±0.2  
Above 5 ~ 15 ±0.3  
Above 15 ~ 30 ±0.4  
Above 30 ~ 50 ±0.5  
Angle ±0.3

3RD. ANGEL'S



UNITS

MM

|              |          |           |          |                                 |
|--------------|----------|-----------|----------|---------------------------------|
| DRAWN BY:    | DATE     | MAT'L     | TITLE    | CONNECTOR                       |
| Jack Lu      | 05/13/21 |           |          |                                 |
| CHECKED BY:  | DATE     | FINISH    | MODLE    | USB AF 3.0 沉板上H3.50mm 無捲邊 GEN 2 |
| Jacky Chen   | 05/13/21 |           |          |                                 |
| APPROVED BY: | DATE     | SCALE     | DWG NO.  | SUA-110E16-32x-S242             |
| Tony Kao     | 05/13/21 | 1 : 1     |          |                                 |
|              |          | SHEET NO. | PART NO. | SUA-110E16-32x-S242             |
|              |          | 1 of 1    |          |                                 |
|              |          |           |          | SIZE A4                         |
|              |          |           |          | VER R                           |

| ITEM NO. | DESCRIPTION | DRAWN | DATE |
|----------|-------------|-------|------|
|          |             |       |      |
|          |             |       |      |
|          |             |       |      |